

MRB TNH230

规格 R0.05×颈角3°~R2×颈角1°
Size R0.05×neck taper angle3°~R2×neck taper angle1°



无限白金涂层 长颈锥形2刃球头铣刀

共有187种规格
Total 187 sizes

MUGEN COATING PREMIUM 2-Flute Long Taper Neck Ball End Mill

采用锥颈形状，大幅提高刀具刚性。
可使用与加工面倾斜角角度相同的颈角

Taper neck to improve tool rigidity.
Option of same taper angle as inclined working angle

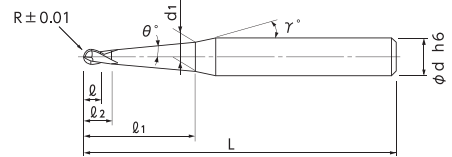

- 锥颈形状的球头铣刀，能实现深沟加工的高精度化。
- 采用优化的锥颈形状和无限白金涂层，加工高硬度钢时可更充分发挥特长。
- 采用通用性高的2刃设计，共有187种规格。
- Taper neck type ball end mill improves accuracy for deep milling.
- Optimized taper neck design and MUGEN COATING PREMIUM realized to show its higher ability for hardened steels.
- Lineup of total 187 size with high versatility 2-flute end mills.

※可选择颈角(θ)与加工面倾斜角角度相同的刀具。

※Please select the tool with the same neck angle as the inclined angle of the milling surface.

【颈部形状】

所述的颈角2(γ)的值仅为参考值。如果担心加工材料和颈部会干涉时，请务必实际测量进行确认。

【Neck Shape】

(γ) is reference value. Tool measurement required in order to avoid interference to the work material.

★ 返修对应 (柄长须在15mm以上。详情请咨询本公司。)

单位 [规格: mm / 价格: 日元]
Unit [Size: mm / Retail Price: JPY]

产品代码 Code No.	(R)球头半径 Radius	(θ)颈角※ Neck Taper Angle	(ℓ1)颈长 Under Neck Length	(d1)颈径 Neck Dia.	(ℓ)刃长 Length of Cut	(ℓ2)颈长2 Under Neck Length 2	(γ)颈角2 Neck Taper Angle 2	(α)有效斜度 Effective Inclined Angle	(d)柄径 Shank Dia.	(L)全长 Overall Length	定价(日元) Retail Price	
08-00588-00571	R0.05	3°	0.5	0.14	0.07	0.2	12°	2°59'	4	50	12,100	
08-00588-00573			0.75	0.17	0.07	0.2	12°	2°59'	4	50	12,500	
08-00588-00771	R0.075	3°	1	0.24	0.1	0.3	12°	2°59'	4	50	13,700	
08-00588-00773			1.5	0.29	0.1	0.3	12°	2°59'	4	50	14,200	
08-00588-01021	R0.1	30°	1.5	0.21	0.15	0.3	12°	0°29'	4	50	10,400	
08-00588-01023			2	0.22	0.15	0.3	12°	0°28'	4	50	10,900	
08-00588-01031		1°	1.5	0.24	0.15	0.3	12°	0°58'	4	50	10,400	
08-00588-01033			2	0.25	0.15	0.3	12°	0°58'	4	50	10,900	
08-00588-01041		1°30'	1.5	0.26	0.15	0.3	12°	1°29'	4	50	10,400	
08-00588-01043			2	0.29	0.15	0.3	12°	1°28'	4	50	10,900	
08-00588-01051		2°	1.5	0.29	0.15	0.3	12°	1°59'	4	50	10,400	
08-00588-01053			2	0.32	0.15	0.3	12°	1°59'	4	50	10,900	
08-00588-01073		3°	3	0.49	0.15	0.3	12°	2°59'	4	50	10,400	
08-00588-01075			5	0.7	0.15	0.3	12°	2°59'	4	50	10,900	
08-00588-01093		5°	3	0.7	0.15	0.3	12°	4°59'	4	50	10,400	
08-00588-01095			5	1.05	0.15	0.3	12°	4°59'	4	50	10,900	
08-00588-01521		R0.15	30°	2	0.32	0.2	0.45	12°	0°28'	4	50	10,400
08-00588-01523				3	0.34	0.2	0.45	12°	0°29'	4	50	10,900
08-00588-01531			1°	2	0.35	0.2	0.45	12°	0°59'	4	50	10,400
08-00588-01533				3	0.39	0.2	0.45	12°	0°59'	4	50	10,900
08-00588-01541	1°30'		2	0.38	0.2	0.45	12°	1°29'	4	50	10,400	
08-00588-01543			3	0.44	0.2	0.45	12°	1°29'	4	50	10,900	
08-00588-01551	2°		2	0.42	0.2	0.45	12°	1°58'	4	50	10,400	
08-00588-01553			3	0.49	0.2	0.45	12°	1°59'	4	50	10,900	
08-00588-01572	3°		2	0.48	0.2	0.45	12°	2°59'	4	50	10,400	
08-00588-01573			3	0.59	0.2	0.45	12°	2°59'	4	50	10,600	
08-00588-01575	5°		5	0.8	0.2	0.45	12°	2°59'	4	50	10,900	
08-00588-01577			7	1.01	0.2	0.45	12°	2°59'	4	50	11,100	
08-00588-01593	7°		3	0.79	0.2	0.45	12°	4°59'	4	50	10,600	
08-00588-01595			5	1.14	0.2	0.45	12°	4°59'	4	50	10,900	
08-00588-01597	7°		7	1.49	0.2	0.45	12°	4°59'	4	50	11,100	
08-00588-02021			R0.2	30°	3	0.43	0.3	0.6	12°	0°29'	4	50
08-00588-02023	4	0.45			0.3	0.6	12°	0°29'	4	50	8,100	
08-00588-02025	6	0.48			0.3	0.6	12°	0°29'	4	50	8,500	
08-00588-02031	1°	3		0.48	0.3	0.6	12°	0°59'	4	50	8,100	
08-00588-02033		4		0.51	0.3	0.6	12°	0°59'	4	50	8,100	
08-00588-02035	1°30'	6		0.58	0.3	0.6	12°	0°59'	4	50	8,500	
08-00588-02041		3°	3	0.53	0.3	0.6	12°	1°29'	4	50	8,100	
08-00588-02043			4	0.58	0.3	0.6	12°	1°29'	4	50	8,100	
08-00588-02045		6°	6	0.68	0.3	0.6	12°	1°29'	4	50	8,500	
08-00588-02051			2°	3	0.58	0.3	0.6	12°	1°59'	4	50	8,100
08-00588-02053		4		0.65	0.3	0.6	12°	1°59'	4	50	8,100	
08-00588-02055	6	0.79	0.3	0.6	12°	1°59'	4	50	8,500			

订购方法
How to Order

请指定MRB TNH230 球头半径(R)×颈角(θ)×颈长(ℓ1)。
When you order, indicate MRB TNH230 (R)×(θ)×(ℓ1).

加工案例
Machining case

M-030

常规系列
无限白金涂层
长颈造型
Regular Line
MUGEN PREMIUM
Long Neck Type

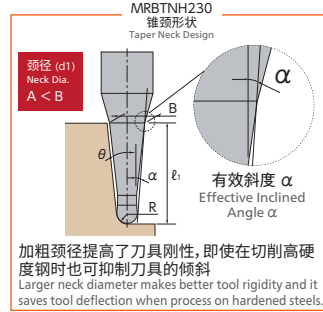
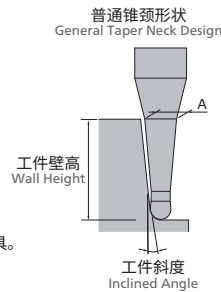

※可选择颈角(θ)与加工面倾斜角角度相同的刀具。
 ※Please select the tool with the same neck angle as the inclined angle of the milling surface.

★ 返修对应 (柄长须在15mm以上。详情请咨询本公司。)

单位 [规格: mm / 价格: 日元]
 Unit [Size: mm / Retail Price: JPY]

产品代码 Code No.	(R)球头半径 Radius	(θ)颈角※ Neck Taper Angle	(ℓ_1)颈长 Under Neck Length	(d1)颈径 Neck Dia.	(ℓ)刀长 Length of Cut	(ℓ_2)颈长2 Under Neck Length 2	(γ)颈角2 Neck Taper Angle 2	(α)有效斜度 Effective Inclined Angle	(d)柄径 Shank Dia.	(L)全长 Overall Length	定价(日元) Retail Price	
08-00588-02073	R0.2	3°	5	0.88	0.3	0.6	12°	2°59'	4	50	8,100	
08-00588-02075			7	1.09	0.3	0.6	12°	2°59'	4	50	8,500	
08-00588-02093		5°	5	1.22	0.3		12°	4°59'	4	50	8,100	
08-00588-02095			7	1.57	0.3	0.6	12°	4°59'	4	50	8,500	
08-00588-02521	R0.25	30'	4	0.54	0.35	0.75	12°	0°29'	4	50	7,700	
08-00588-02523			5	0.56	0.35	0.75	12°	0°29'	4	50	7,900	
08-00588-02531		1°	4	0.61	0.35	0.75	12°	0°59'	4	50	7,700	
08-00588-02533			5	0.64	0.35	0.75	12°	0°59'	4	50	7,900	
08-00588-02541		1°30'	4	0.67	0.35	0.75	12°	1°29'	4	50	7,700	
08-00588-02543			5	0.73	0.35	0.75	12°	1°29'	4	50	7,900	
08-00588-02551		2°	4	0.74	0.35	0.75	12°	1°59'	4	50	7,700	
08-00588-02553			5	0.81	0.35	0.75	12°	1°59'	4	50	7,900	
08-00588-03021		R0.3	30'	4	0.64	0.45	0.9	12°	0°29'	4	50	7,100
08-00588-03023				5	0.66	0.45	0.9	12°	0°29'	4	50	7,500
08-00588-03025				6	0.67	0.45	0.9	12°	0°29'	4	50	7,500
08-00588-03027				8	0.71	0.45	0.9	12°	0°29'	4	50	7,700
08-00588-03031	1°		4	0.7	0.45	0.9	12°	0°59'	4	50	7,100	
08-00588-03033			5	0.74	0.45	0.9	12°	0°59'	4	50	7,500	
08-00588-03035			6	0.77	0.45	0.9	12°	0°59'	4	50	7,500	
08-00588-03037			8	0.84	0.45	0.9	12°	0°59'	4	50	7,700	
08-00588-03041	1°30'		4	0.77	0.45	0.9	12°	1°29'	4	50	7,100	
08-00588-03043			5	0.82	0.45	0.9	12°	1°29'	4	50	7,500	
08-00588-03045			6	0.87	0.45	0.9	12°	1°29'	4	50	7,500	
08-00588-03047			8	0.98	0.45	0.9	12°	1°29'	4	50	7,700	
08-00588-03053	2°	5	0.9	0.45	0.9	12°	1°59'	4	50	7,500		
08-00588-03055		6	0.97	0.45	0.9	12°	1°59'	4	50	7,500		
08-00588-03057		8	1.11	0.45	0.9	12°	1°59'	4	50	7,700		
08-00588-03072		4	0.96	0.45	0.9	12°	2°59'	4	50	7,500		
08-00588-03073	3°	5	1.07	0.45	0.9	12°	2°59'	4	50	7,500		
08-00588-03075		7	1.28	0.45	0.9	12°	2°59'	4	50	7,700		
08-00588-03092		5°	5	1.4	0.45	0.9	12°	4°59'	4	50	7,500	
08-00588-03094			7	1.75	0.45	0.9	12°	4°59'	4	50	7,700	
08-00588-04021	R0.4	30'	8	0.89	0.6	1.2	12°	0°29'	4	60	8,000	
08-00588-04023			12	0.96	0.6	1.2	12°	0°29'	4	60	8,400	
08-00588-04031		1°	8	1.03	0.6	1.2	12°	0°59'	4	60	8,000	
08-00588-04033			12	1.17	0.6	1.2	12°	0°59'	4	60	8,400	
08-00588-04041		1°30'	8	1.16	0.6	1.2	12°	1°29'	4	60	8,000	
08-00588-04043			12	1.37	0.6	1.2	12°	1°29'	4	60	8,400	
08-00588-04051		2°	8	1.29	0.6	1.2	12°	1°59'	4	60	8,000	
08-00588-04053			12	1.57	0.6	1.2	12°	1°59'	4	60	8,400	
★ 08-00588-05021		R0.5	30'	6	1.05	0.75	1.5	12°	0°29'	4	60	5,700
★ 08-00588-05022				8	1.08	0.75	1.5	12°	0°29'	4	60	6,200
★ 08-00588-05023				10	1.12	0.75	1.5	12°	0°29'	4	60	6,800
★ 08-00588-05024				12	1.15	0.75	1.5	12°	0°29'	4	60	6,800
★ 08-00588-05025	16			1.22	0.75	1.5	12°	0°29'	4	60	7,100	
★ 08-00588-05026	20			1.29	0.75	1.5	12°	0°29'	4	70	8,600	

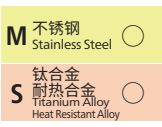

常规系列
 无限白金涂层
 长颈造型
 Regular Line
 MUGEN PREMIUM
 Long Neck Type

MRBTN230

无限白金涂层 长颈锥形2刃球头铣刀

MUGEN COATING PREMIUM 2-Flute Long Taper Neck Ball End Mill



[颈部形状]

所述的颈角 $2(\gamma)$ 的值仅为参考值。如果担心加工材料和颈部会干涉时，请务必实际测量进行确认。
(Neck Shape)
 (γ) is reference value. Tool measurement required in order to avoid interference to the work material.

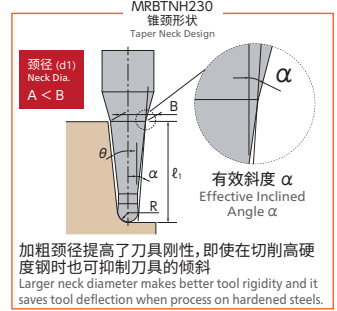
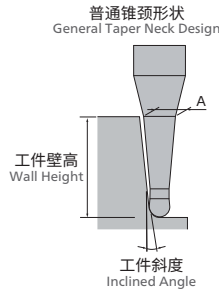

★ 返修对应 (柄长须在15mm以上。详情请咨询本公司。)

单位 [规格: mm / 价格: 日元] Unit [Size: mm / Retail Price: JPY]

产品代码 Code No.	(R)球头半径 Radius	(θ)颈角 [※] Neck Taper Angle	(l_1)颈长 Under Neck Length	(d1)颈径 Neck Dia.	(l)刃长 Length of Cut	(l_2)颈长2 Under Neck Length 2	(γ)颈角2 Neck Taper Angle 2	(α)有效斜度 Effective Inclined Angle	(d)柄径 Shank Dia.	(L)全长 Overall Length	定价(日元) Retail Price	
★ 08-00588-05027	R0.5	30'	25	1.38	0.75	1.5	12°	0°29'	4	70	9,100	
★ 08-00588-05028			30	1.47	0.75	1.5	12°	0°29'	4	70	9,500	
★ 08-00588-05031			1°	6	1.15	0.75	1.5	12°	0°59'	4	60	5,700
★ 08-00588-05032				8	1.22	0.75	1.5	12°	0°59'	4	60	6,200
★ 08-00588-05033				10	1.29	0.75	1.5	12°	0°59'	4	60	6,800
★ 08-00588-05034				12	1.36	0.75	1.5	12°	0°59'	4	60	6,800
★ 08-00588-05035		16		1.5	0.75	1.5	12°	0°59'	4	60	7,100	
★ 08-00588-05036		20		1.63	0.75	1.5	12°	0°59'	4	70	8,600	
★ 08-00588-05037		25	1.81	0.75	1.5	12°	0°59'	4	70	9,100		
★ 08-00588-05038		30	1.98	0.75	1.5	12°	0°59'	4	70	9,500		
★ 08-00588-05041		1°30'	6	1.24	0.75	1.5	12°	1°29'	4	60	5,700	
★ 08-00588-05042			8	1.35	0.75	1.5	12°	1°29'	4	60	6,200	
★ 08-00588-05043			10	1.45	0.75	1.5	12°	1°29'	4	60	6,800	
★ 08-00588-05044			12	1.56	0.75	1.5	12°	1°29'	4	60	6,800	
★ 08-00588-05045			16	1.77	0.75	1.5	12°	1°29'	4	60	7,100	
★ 08-00588-05046			20	1.98	0.75	1.5	12°	1°29'	4	70	8,600	
★ 08-00588-05047		25	2.24	0.75	1.5	12°	1°29'	4	70	9,100		
★ 08-00588-05048		30	2.5	0.75	1.5	12°	1°29'	4	70	9,500		
★ 08-00588-05052		2°	8	1.48	0.75	1.5	12°	1°59'	4	60	6,200	
★ 08-00588-05053			10	1.62	0.75	1.5	12°	1°59'	4	60	6,800	
★ 08-00588-05056			20	2.32	0.75	1.5	12°	1°59'	4	70	8,600	
★ 08-00588-05058			30	3.01	0.75	1.5	12°	1°59'	4	70	9,500	
★ 08-00588-05073			3°	10	1.95	0.75	1.5	12°	2°59'	4	60	6,800
★ 08-00588-05076				20	3	0.75	1.5	12°	2°59'	4	70	8,600
★ 08-00588-05078	30	4.05		0.75	1.5	12°	2°59'	6	70	9,900		
★ 08-00588-07521	R0.75	30'	10	1.61	1.1	2.25	12°	0°29'	4	60	7,100	
★ 08-00588-07523			15	1.69	1.1	2.25	12°	0°29'	4	60	7,800	
★ 08-00588-07525			20	1.78	1.1	2.25	12°	0°29'	4	70	8,600	
★ 08-00588-07527			25	1.87	1.1	2.25	12°	0°29'	4	70	9,500	
★ 08-00588-07529		30	1.96	1.1	2.25	12°	0°29'	4	70	10,800		
★ 08-00588-07531		1°	10	1.77	1.1	2.25	12°	0°59'	4	60	7,100	
★ 08-00588-07533			15	1.94	1.1	2.25	12°	0°59'	4	60	7,800	
★ 08-00588-07535			20	2.12	1.1	2.25	12°	0°59'	4	70	8,600	
★ 08-00588-07537			25	2.29	1.1	2.25	12°	0°59'	4	70	9,500	
★ 08-00588-07539			30	2.47	1.1	2.25	12°	0°59'	4	70	10,800	
★ 08-00588-07541			1°30'	10	1.93	1.1	2.25	12°	1°29'	4	60	7,100
★ 08-00588-07543		15		2.19	1.1	2.25	12°	1°29'	4	60	7,800	
★ 08-00588-07545	20	2.45		1.1	2.25	12°	1°29'	4	70	8,600		
★ 08-00588-07551	10	2.09		1.1	2.25	12°	1°59'	4	60	7,100		
★ 08-00588-07553	2°	15	2.44	1.1	2.25	12°	1°59'	4	60	7,800		
★ 08-00588-07555		20	2.79	1.1	2.25	12°	1°59'	4	70	9,500		
★ 08-00588-10021		R1	30'	12	2.14	1.5	3	12°	0°29'	4	60	6,300
★ 08-00588-10022	16			2.21	1.5	3	12°	0°29'	4	60	6,500	

订购方法
How to Order

请指定MRBTN230 球头半径(R)×颈角(θ)×颈长(l_1)。
When you order, indicate MRBTN230 (R)×(θ)×(l_1).

加工案例
Machining case

M-030



常规系列
无限白金涂层
长颈造型
Regular Line
MUGEN PREMIUM
Long Neck Type

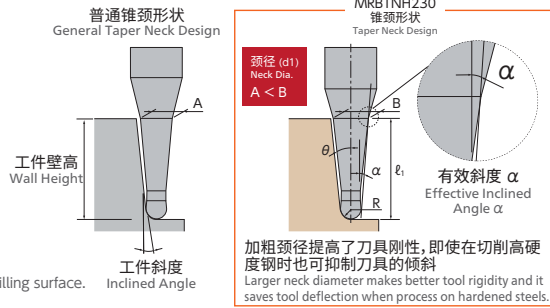

※可选择颈角(θ)与加工面倾斜角角度相同的刀具。

※Please select the tool with the same neck angle as the inclined angle of the milling surface.

★ 返修对应 (柄长须在15mm以上。详情请咨询本公司。)

单位 [规格: mm / 价格: 日元] Unit [Size: mm / Retail Price: JPY]

产品代码 Code No.	(R)球头半径 Radius	(θ)颈角※ Neck Taper Angle	(ℓ1)颈长 Under Neck Length	(d1)颈径 Neck Dia.	(ℓ)刃长 Length of Cut	(ℓ2)颈长2 Under Neck Length 2	(γ)颈角2 Neck Taper Angle 2	(α)有效斜度 Effective Inclined Angle	(d)柄径 Shank Dia.	(L)全长 Overall Length	定价(日元) Retail Price	
★ 08-00588-10023	R1	30°	20	2.28	1.5	3	12°	0°29'	4	70	7,800	
★ 08-00588-10024			25	2.37	1.5	3	12°	0°29'	4	70	8,600	
★ 08-00588-10025			30	2.46	1.5	3	12°	0°29'	4	70	9,500	
★ 08-00588-10026			35	2.54	1.5	3	12°	0°29'	4	80	10,300	
★ 08-00588-10027			40	2.63	1.5	3	12°	0°29'	4	80	11,100	
★ 08-00588-10028			50	2.81	1.5	3	12°	0°30'	4	90	12,600	
★ 08-00588-10031		1°	12	2.33	1.5	3	12°	0°59'	4	60	6,300	
★ 08-00588-10032			16	2.47	1.5	3	12°	0°59'	4	60	6,500	
★ 08-00588-10033			20	2.61	1.5	3	12°	0°59'	4	70	7,800	
★ 08-00588-10034			25	2.79	1.5	3	12°	0°59'	4	70	8,600	
★ 08-00588-10035			30	2.96	1.5	3	12°	0°59'	4	70	9,500	
★ 08-00588-10036			35	3.14	1.5	3	12°	0°59'	6	80	12,800	
★ 08-00588-10037		40	3.31	1.5	3	12°	0°59'	6	80	13,400		
★ 08-00588-10038		50	3.66	1.5	3	12°	0°59'	6	90	14,900		
★ 08-00588-10041		1°30'	12	2.53	1.5	3	12°	1°29'	4	60	6,300	
★ 08-00588-10042			16	2.74	1.5	3	12°	1°29'	4	60	6,500	
★ 08-00588-10043			20	2.95	1.5	3	12°	1°29'	4	70	7,800	
★ 08-00588-10044			25	3.21	1.5	3	12°	1°29'	4	70	8,600	
★ 08-00588-10045			30	3.47	1.5	3	12°	1°29'	6	70	11,700	
★ 08-00588-10046			35	3.73	1.5	3	12°	1°29'	6	80	12,800	
★ 08-00588-10047		2°	40	3.99	1.5	3	12°	1°29'	6	80	13,400	
★ 08-00588-10048			50	4.52	1.5	3	12°	1°30'	6	90	14,900	
★ 08-00588-10051			12	2.72	1.5	3	12°	1°59'	4	60	6,300	
★ 08-00588-10052			16	3	1.5	3	12°	1°59'	4	60	6,500	
★ 08-00588-10053			20	3.28	1.5	3	12°	1°59'	4	70	8,200	
★ 08-00588-10054			25	3.63	1.5	3	12°	1°59'	6	70	9,500	
★ 08-00588-10055		R1.5	30	3.98	1.5	3	12°	1°59'	6	70	11,700	
★ 08-00588-10057			40	4.67	1.5	3	12°	1°59'	6	80	13,400	
★ 08-00588-10058			50	5.37	1.5	3	12°	2°00'	6	90	14,900	
★ 08-00588-15021			30°	15	3.13	2.5	4.5	12°	0°29'	6	70	9,000
★ 08-00588-15022	20			3.22	2.5	4.5	12°	0°29'	6	70	9,600	
★ 08-00588-15023	25			3.31	2.5	4.5	12°	0°29'	6	70	10,300	
★ 08-00588-15024	30	3.4		2.5	4.5	12°	0°29'	6	70	11,100		
★ 08-00588-15025	40	3.57		2.5	4.5	12°	0°29'	6	80	12,300		
★ 08-00588-15026	50	3.74		2.5	4.5	12°	0°29'	6	90	14,300		
★ 08-00588-15031	1°	15	3.37	2.5	4.5	12°	0°59'	6	70	9,000		
★ 08-00588-15032		20	3.54	2.5	4.5	12°	0°59'	6	70	9,600		
★ 08-00588-15033		25	3.72	2.5	4.5	12°	0°59'	6	70	10,300		
★ 08-00588-15034		30	3.89	2.5	4.5	12°	0°59'	6	70	11,100		
★ 08-00588-15035		40	4.24	2.5	4.5	12°	0°59'	6	80	12,300		
★ 08-00588-15036		50	4.59	2.5	4.5	12°	0°59'	6	90	14,300		
★ 08-00588-15041	1°30'	15	3.61	2.5	4.5	12°	1°29'	6	70	9,000		
★ 08-00588-15042		20	3.87	2.5	4.5	12°	1°29'	6	70	9,600		
★ 08-00588-15043		25	4.13	2.5	4.5	12°	1°29'	6	70	10,300		
★ 08-00588-15044		30	4.39	2.5	4.5	12°	1°29'	6	70	11,100		
★ 08-00588-15045		40	4.91	2.5	4.5	12°	1°29'	6	80	12,300		
★ 08-00588-15046		50	5.44	2.5	4.5	12°	1°29'	6	90	14,300		
★ 08-00588-15051	2°	15	3.84	2.5	4.5	12°	1°59'	6	70	9,000		
★ 08-00588-15052		20	4.19	2.5	4.5	12°	1°59'	6	70	9,600		
★ 08-00588-15054		30	4.89	2.5	4.5	12°	1°59'	6	70	12,900		
★ 08-00588-20031		R2	1°	20	4.57	3	6	12°	0°59'	6	80	11,900
★ 08-00588-20033				30	4.92	3	6	12°	0°59'	6	80	11,900
★ 08-00588-20035				40	5.26	3	6	12°	0°59'	6	80	15,600
★ 08-00588-20036	50			5.62	3	6	12°	0°59'	6	90	16,500	
★ 08-00588-20037	61.1			6	3	6	-	0°59'	6	110	17,800	

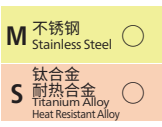

常规系列
无限白金涂层
长颈造型
Regular Line
MUGEN PREMIUM
Long Neck Type